



Ice Cream Display Showcase
Model FR-CN-1200-D
Item 43118
Instruction Manual



Revised - 12/02/2020



Toll Free: 1-800-465-0234
Fax: 905-607-0234
Email: service@omcan.com
www.omcan.com

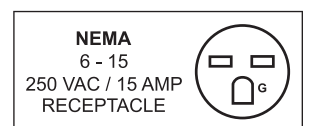

Table of Contents

Model FR-CN-1200-D

Section	Page
Disclaimer -----	3
General Information -----	4 - 5
Safety and Warranty -----	5 - 7
Technical Specifications -----	7
Operation -----	8
Maintenance -----	8 - 9
Troubleshooting -----	9 - 10
Parts Breakdown -----	11 - 12
Electrical Schematics -----	13
Notes -----	14
Warranty Registration -----	15

Disclaimer

OMCAN IS NOT RESPONSIBLE FOR ANY DAMAGES DUE TO WATER LEAKS. WARRANTY FOR WATER LEAKS IS VOID IF THE AMBIENT ROOM TEMPERATURE EXCEEDS 75°F AND 55% RELATIVE HUMIDITY, AND THE APPLIANCE DRAIN IS NOT CONNECTED DIRECTLY TO A FLOOR DRAIN.

General Information

Omcan Manufacturing and Distributing Company Inc., Food Machinery of America, Inc. dba Omcan and Omcan Inc. are not responsible for any harm or injury caused due to any person's improper or negligent use of this equipment. The product shall only be operated by someone over the age of 18, of sound mind, and not under the influence of any drugs or alcohol, who has been trained in the correct operation of this machine, and is wearing authorized, proper safety clothing. Any modification to the machine voids any warranty, and may cause harm to individuals using the machine or in the vicinity of the machine while in operation.

CHECK PACKAGE UPON ARRIVAL

Upon receipt of an Omcan shipment please inspect for external damage. If no damage is evident on the external packaging, open carton to ensure all ordered items are within the box, and there is no concealed damage to the machine. If the package has suffered rough handling, bumps or damage (visible or concealed), please note it on the bill of lading before accepting the delivery and contact Omcan within 24 hours, so we may initiate a claim with the carrier. A detailed report on the extent of the damage caused to the machine must be filled out within three days, from the delivery date shown in the shipping documents. Omcan has no recourse for damaged products that were shipped collect or third party.

Before operating any equipment, always read and familiarize yourself with all operation and safety instructions.

Omcan would like to thank you for purchasing this machine. It's of the utmost importance to save these instructions for future reference. Also save the original box and packaging for shipping the equipment if servicing or returning of the machine is required.

Omcan Fabrication et distribution Compagnie Limitée et Food Machinery d'Amérique, dba Omcan et Omcan Inc. ne sont pas responsables de tout dommage ou blessure causé du fait que toute personne ait utilisé cet équipement de façon irrégulière. Le produit ne doit être exploité que par quelqu'un de plus de 18 ans, sain d'esprit, et pas sous l'influence d'une drogue ou d'alcool, qui a été formé pour utiliser cette machine correctement, et est vêtu de vêtements de sécurité appropriés. Toute modification de la machine annule toute garantie, et peut causer un préjudice à des personnes utilisant la machine ou des personnes à proximité de la machine pendant son fonctionnement.

VÉRIFIEZ LE COLIS DÈS RÉCEPTION

Dès réception d'une expédition d'Omcan veuillez inspecter pour dommages externes. Si aucun dommage n'est visible sur l'emballage externe, ouvrez le carton afin de s'assurer que tous les éléments commandés sont dans la boîte, et il n'y a aucun dommage dissimulé à la machine. Si le colis n'a subi aucune mauvaises manipulations, de bosses ou de dommages (visible ou cachée), notez-le sur le bond de livraison avant d'accepter la livraison et contactez Omcan dans les 24 heures qui suivent, pour que nous puissions engager une réclamation auprès du transporteur. Un rapport détaillé sur l'étendue des dommages causés à la machine doit être rempli dans un délai de trois jours, à compter de la date de livraison indiquée dans les documents d'expédition. Omcan n'a aucun droit de recours pour les produits endommagés qui ont été expédiés ou cueilli par un tiers transporteur.



General Information

Avant d'utiliser n'importe quel équipement, toujours lire et vous familiariser avec toutes les opérations et les consignes de sécurité.

Omcan voudrais vous remercier d'avoir choisi cette machine. Il est primordial de conserver ces instructions pour une référence ultérieure. Également conservez la boîte originale et l'emballage pour l'expédition de l'équipement si l'entretien ou le retour de la machine est nécessaire.

Omcan Empresa De Fabricacion Y Distribucion Inc. Y Maquinaria De Alimentos De America, Inc. dba Omcan y Omcan Inc. no son responsables de ningun daño o perjuicio causado por cualquier persona inadecuada o el uso descuidado de este equipo. El producto solo podra ser operado por una persona mayor de 18 años, en su sano juicio y no bajo alguna influencia de droga o alcohol, y que este ha sido entrenado en el correcto funcionamiento de esta máquina, y ésta usando ropa apropiada y autorizada. Cualquier modificación a la máquina anula la garantía y puede causar daños a las personas usando la máquina mientras esta en el funcionamiento.

REVISE EL PAQUETE A SU LLEGADA

Tras la recepcion de un envio Omcan favor inspeccionar daños externos. Si no hay daños evidentes en el empaque exterior, Habra el carton para asegurarse que todos los articulos solicitados estén dentro de la caja y no encuentre daños ocultos en la máquina. Si el paquete ha sufrido un manejo de poco cuidado, golpes o daños (visible o oculto) por favor anote en la factura antes de aceptar la entrega y contacte Omcan dentro de las 24 horas, de modo que podamos iniciar una reclamación con la compañía. Un informe detallado sobre los daños causados a la máquina debe ser llenado en el plazo de tres días, desde la fecha de entrega que se muestra en los documentos de envío. Omcan no tiene ningun recurso por productos dañados que se enviaron a recoger por terceros.

Antes de utilizar cualquier equipo, siempre leer y familiarizarse con todas las instrucciones de operación y seguridad.

Omcan quisiera darles las gracias por la compra de esta máquina. Es de la máxima importancia para guardar estas instrucciones para referencias en el futuro. También guarde la caja original y el embalaje para envío del equipo si el mantenimiento o la devolución de la máquina es necesaria.

Safety and Warranty

HANDLING AND INSTALLATION

Handle with care Unplug from the wall socket before moving. Never tilt the refrigerator over 45 degrees during handling.	Storage Always store the refrigerator in a dry place.
--	---

Safety and Warranty

<p>Sufficient space To allow for proper air circulation and increased refrigeration capabilities, the refrigerator must have at least 4"/10cm of space between wall/ceiling and the machine.</p>	<p>Proper ventilation Always place the refrigerator in an area with good ventilation. For first time use, set in location and wait at least 2 hours before plugging into wall socket.</p>
<p>Away from heat source Never place the refrigerator near any type of heat source or in direct sunlight, as it reduces refrigeration capabilities.</p>	<p>No heavy load Never put heavy items on top of the refrigerator.</p>
<p>No altercations/tampering Never tamper with or make changes to the refrigerator. Changes and add-ons should not be installed to the inside or outside of the refrigerator.</p>	<p>Stable location Unpack and place the refrigerator on flat, solid ground.</p>

PREPARATION AND POWER SUPPLY

<p>Exclusive power outlet Power supply should be 220V, single phase AC with exclusive single phase three pin outlet (250V/10A) and fuse (6A). The power outlet must be in close proximity to the ground.</p>	<p>No shared power outlets Refrigerator cable should never share the power outlet with any other appliance, as cable will overheat and may result in a fire.</p>
<p>Protect cables Extra caution should be used when handling cables, as broken or damaged cables can cause sparking and may result in a fire.</p>	<p>No water flushing Never flush the refrigerator surface. This can cause leakage, which may result in electrical damage or fire.</p>
<p>Never store flammables and explosives No explosives or flammables should be stored in, or in proximity to, the refrigerator, such as gasoline, alcohol, and adhesives.</p>	<p>No spray Never spray flammables such as paint or coating near the refrigerator. This may cause fire or malfunction.</p>
<p>After power outage After a power outage or the unplugging of the refrigerator, wait at least 5 minutes before plugging it back in.</p>	<p>No medicine Medicine should not be stored inside of the refrigerator.</p>

1 YEAR PARTS AND LABOUR WARRANTY

Within the warranty period, contact Omcan Inc. at 1-800-465-0234 to schedule an Omcan authorized service technician to repair the equipment locally.

Unauthorized maintenance will void the warranty. Warranty covers electrical and part failures not improper use.

Please see <https://omcan.com/disclaimer> for complete info.

Safety and Warranty

WARNING:

The packaging components are classified as normal solid urban waste and can therefore be disposed of without difficulty.

In any case, for suitable recycling, we suggest disposing of the products separately (differentiated waste) according to the current norms.

DO NOT DISCARD ANY PACKAGING MATERIALS IN THE ENVIRONMENT!

Technical Specifications

Model	FR-CN-1200-D
Storage Volume	600 L / 21.2 cu. ft.
Temperature Range	-18° to - 24°C / -0.4° to -11.2°F
Max Ambient Temp Rating	32°C / 90°F
General Rated Input Power	0.65 kW
Defrost Power	1.05 kW
Rated Current	4.6A
Foaming Agent	C5H10
Refrigerant and Injection	R404 (310g)
Type of Climate	4
Lamp Power	6W (LED)
Pan Dimensions	14.1" x 6.5" x 4.5" / 359 x 165 x 114mm
Electrical	220V / 60Hz / 1
Weight	542.3 lbs. / 246 kgs.
Packaging Weight	630.5 lbs. / 286 kgs.
Dimensions	41.9" x 48.8" x 55.5" / 1065 x 1240 x 1410mm
Packaging Dimensions	51.6" x 45" x 61.8" / 1310 x 1145 x 1570mm
Item Number	43118

Operation

BEFORE USE

- Plug refrigerator into the 220V exclusive socket.
- After the refrigerator is running, confirm that air suction/filtration is in working order and that it is sufficiently cold. After checking to make sure the refrigerator is working properly, it may be used.



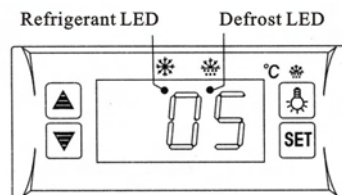



DIGITAL TEMPERATURE CONTROLLER



FEATURES OF FUNCTION

- Small, integrated digital controller, which is applicable to the compressor of 1 Hp. Located behind the front grill.
- Main functions are: Temperature Display/Temperature Control/Manual-Automatic /Light Control/Value Storing/Self-Testing/Parameter Locking.

FRONT PANEL OPERATION

1. Set temperature: Press  button; set temperature will be displayed. Press  or  button to modify and store the displayed value. Press  button to exit the adjustment and display the cold-room temperature.
2. If no button is pressed within 10 seconds, the cold-room temperature will be displayed.
3. Lighting: Press  button to activate light in refrigerator; press again to turn off. Manual start/stop defrost: Press  button and hold for 6 seconds to either defrost or to stop defrost.
4. Refrigeration LED: During refrigeration, the LED is on. When the cold room temperature is constant, the LED is off. During delay start, the LED flashes.
5. Defrost LED: During defrosting, the LED is on. When it stops defrosting, the LED is off. During the delay of defrost, the LED flashed.

Maintenance

CABINET CLEANING

The product should be cleaned once a week with the power supply disconnected. When cleaning please use a mild cleansing agent. Only use a damp cloth.

CLEANING THE FILTER

When message “EE4” appears on the display, please clean the filter immediately. If the error message still appears after cleaning the filter, please contact Omcan.

INSTRUCTIONS FOR CLEANING THE FILTER

1. Remove the four screws from the top of the front grill.
2. Pull out the front grill.
3. Take out the filter.

CHECK FOR LEAKS

Observe all connectors and welding joints for oil stains. This indicates that there is a leak, please call Omcan if you notice any oil stains.

ALWAYS OBSERVE THE OPERATION OF THE UNIT, IN THE EVENT OF ANY ABNORMAL SOUNDS OR SMELLS, OR IF THE UNIT BEGINS TO SMOKE, DISCONNECT THE UNIT FROM THE POWER SUPPLY AND CALL OMCAN.

Troubleshooting

Trouble	Causes	Solutions
Strange noise under the bottom shelf.	Fan blade broken.	Power off and fix the blade.
Non-refrigerating in spite of normal operation.	Unit off.	Power on.
	Melting process.	Stop melting.
	Refrigerant leaking.	Patch the leak and refill refrigerant.
	Unit failure.	Call Omcan.
Weak air from air curtain, and higher cabinet temperature.	Evaporator blocked by frost.	Increase melting frequency.
	Inside fan damaged.	Replace the fan.
	Too low point of temperature controller.	Adjust the set point.
	Vent blocked by storage.	Remove the storage.
Normal air curtain, but higher cabinet temperature.	Insufficient refrigerant.	Refill the refrigerant.
	Too high set point of temperature controllers.	Adjust the set point for the temperature controller.
	The wind curtain disturbed by strong air flow.	Removing the disturbing factors.
	Ambient temperature or humidity beyond standards.	Improve the conditions.

Troubleshooting

Melting water overflows.	Heating pipe for melting water damaged.	Replace the heating pipe.
	Water level controller failure.	Replace the water level controller.
	Ambient temperature or humidity beyond standards.	Improve the conditions.
Normal air curtain, but periodical fluctuation of cabinet temperature.	Condenser contaminated.	Clean the condenser.
	Poor venting of the unit.	Improve the venting conditions.
	Heat protection of compressor failure.	Replace the heat protection.
	Capillary is blocked by ice.	Replace the drying filter.
	Temperature controller failure.	Replace the temperature controller.

NOTE

Following occurrences are not problems:

- The murmur of water is heard when the refrigerator is working. It is a normal occurrence as the coolant is circulating in the system.
- When the weather is damp, condensation might be found on the outside of the refrigerator. It is caused by high humidity. Simply use cloth to wipe it off.

Parts Breakdown

Model FR-CN-1200-D 43118

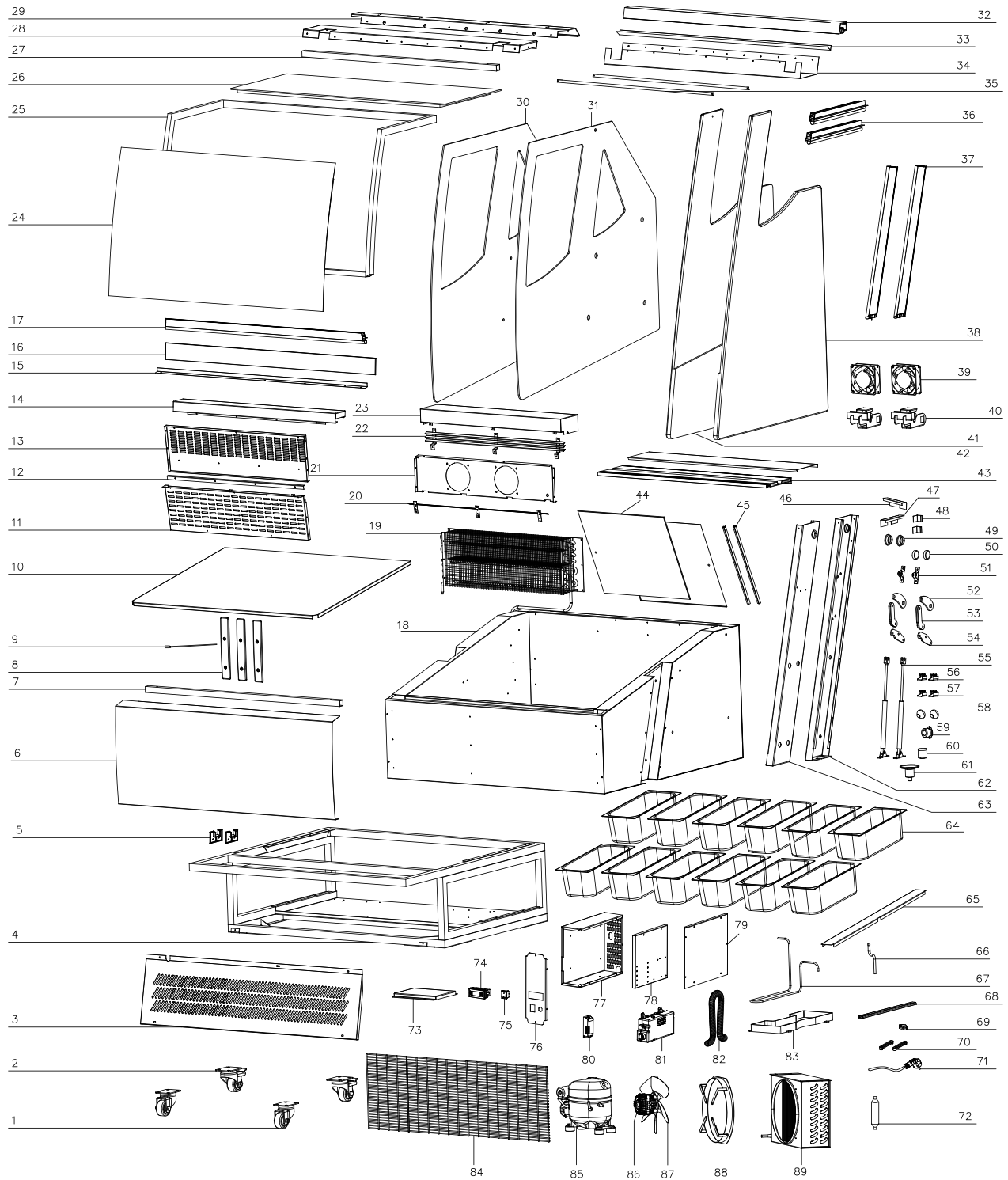

Parts Breakdown

Model FR-CN-1200-D 43118

Item No.	Description	Position	Item No.	Description	Position	Item No.	Description	Position
79763	Swivel Front Castor without Brake for 43118	1	62869	Right Glass for 43118	31	62899	Sewer Joints Large for 43118	61
71042	Rear Swivel Castor with Brake for 43118	2	62870	On the Beam for 43118	32	62900	Right Column for 43118	62
62841	Before the Wind Board for 43118	3	62871	Door Seal On for 43118	33	62901	Left Column for 43118	63
62842	Base for 43118	4	62872	Rocker Under the Cover for 43118	34	62902	Ice Cream Pan 360x165x120mm for 43118	64
62843	Crosspiece Support for 43118	5	62873	LED Light for 43118	35	62903	Middle Bar for 43118	65
62844	Front Decorative Panels for 43118	6	62874	Door Seal-1 for 43118	36	62904	Return Air Tube for 43118	66
62845	Crossed Square Tube for 43118	7	62875	Door Seal-2 for 43118	37	62905	High Pressure Pipe for 43118	67
62846	Front Decorative Panels Supporting Item for 43118	8	62876	Right Trim Plate for 43118	38	62906	Slide Rails for 43118	68
62847	Waterproof Power Cord for 43118	9	62877	Evaporator Fan for 43118	39	62907	Pressure Plate for 43118	69
62848	Ice Cream Barrels Floor for 43118	10	62878	Rocker Arm for 43118	40	62908	High Pressure Pipe Block for 43118	70
62849	Front Bucket Fixed Plate for 43118	11	62879	Left Trim Plate for 43118	41	62909	Power Cable for 43118	71
62850	Front Bucket Baffle Fixed Strip for 43118	12	62880	Rear Beam Cover for 43118	42	30624	Dry Filter for 43118	72
62851	Back Bucket Fixed Plate for 43118	13	62881	Rear Beam for 43118	43	62910	Compressor Fixing Plate for 43118	73
62852	Front Baffle for 43118	14	62882	Door Glass for 43118	44	62911	Thermostat for 43118	74
62853	Front Baffle Glass Fixing Strip for 43118	15	62883	Type A Seal for 43118	45	62912	Switch for 43118	75
62854	Glass Baffle for 43118	16	62884	Top Left Decorative Plate Fixture for 43118	46	62913	Temperature Control Panel for 43118	76
62855	Door Seal-3 for 43118	17	62885	Top Right Decorative Plate Fixture for 43118	47	62914	Power Control Box for 43118	77
62856	Foam Bucket for 43118	18	62886	Rear Decorative Plate Fixture for 43118	48	62915	Power Box Base for 43118	78
62857	Evaporator for 43118	19	62887	Bushings for 43118	49	62916	Power Box Cover for 43118	79
62858	Forward Air Outlet for 43118	20	62888	Bearing for 43118	50	60145	#6 Driver for 43118	80
62859	Evaporator Fan Fixing Plate for 43118	21	62889	Pole Head for 43118	51	62917	Motherboard Fixing Box for 43118	81
62860	After the Outlet for 43118	22	62890	On the Hinge for 43118	52	62918	Bellows for 43118	82
62861	Back Baffle for 43118	23	62891	In the Hinge for 43118	53	62919	Water Box for 43118	83
62862	Front Glass for 43118	24	62892	Under the Hinge for 43118	54	62920	Net Cover for 43118	84
62863	Front Door Frame for 43118	25	62893	Gas Spring for 43118	55	62921	Compressor for 43118	85
62864	Top Glass for 43118	26	62894	Front Door Frame Left Corner for 43118	56	62922	Condenser Motor for 43118	86
62865	Rocker Square Tube for 43118	27	62895	Front Door Frame Right Corner for 43118	57	62923	Leaves for 43118	87
62866	Rocker Cover Plate for 43118	28	62896	Door Handle for 43118	58	62924	Flange for 43118	88
62867	Curtain Fixed Plate for 43118	29	62897	Waterproof Thermostat/Defrost Termination Switch for 43118	59	62925	Condenser for 43118	89
62868	Left Glass for 43118	30	62898	Sewer Joints are Small for 43118	60			

Electrical Schematics

Model FR-CN-1200-D 43118

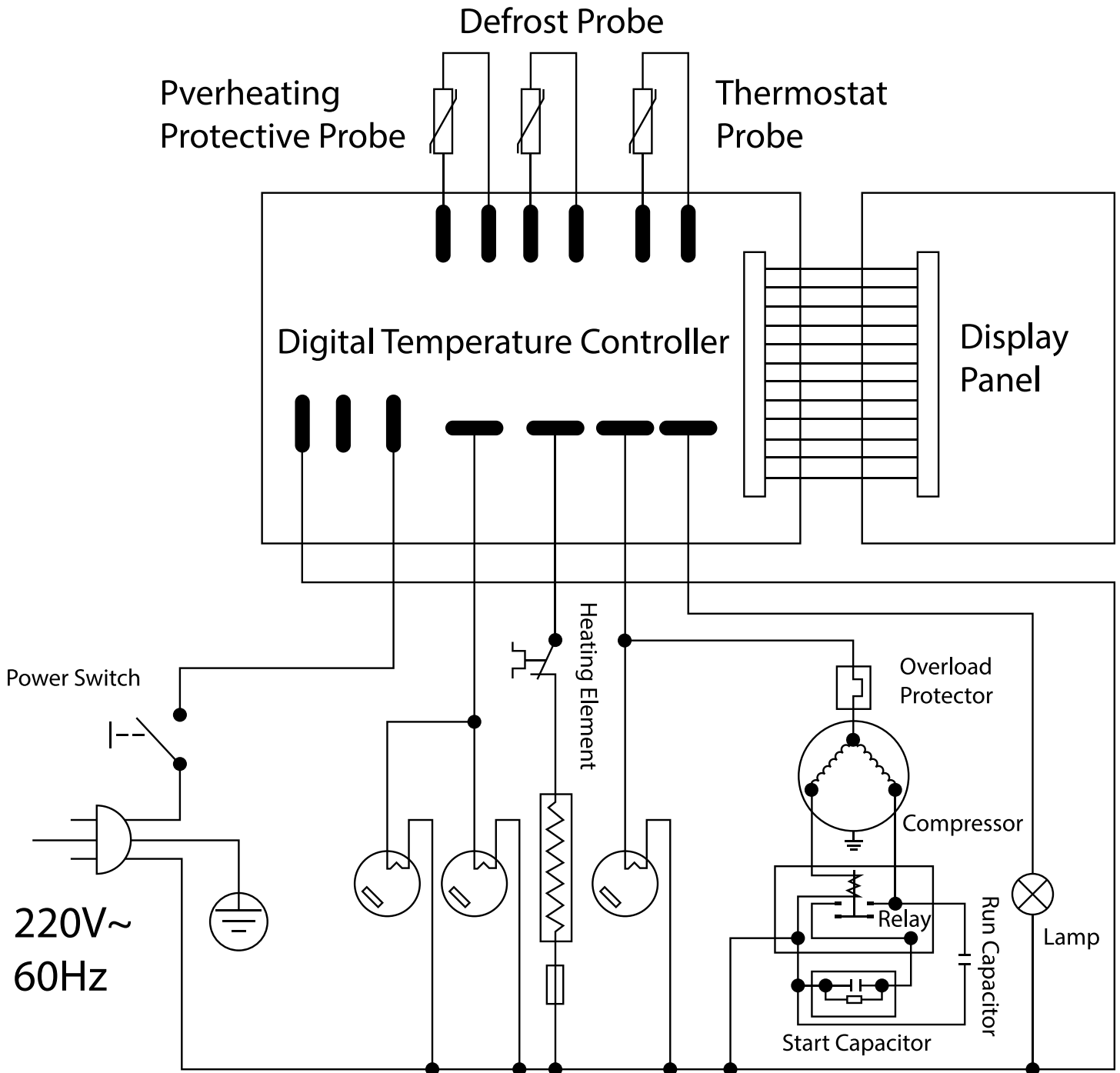



Warranty Registration

Thank you for purchasing an Omcan product. To register your warranty for this product, complete the information below, tear off the card at the perforation and then send to the address specified below. You can also register online by visiting:

Merci d'avoir acheté un produit Omcan. Pour enregistrer votre garantie pour ce produit, complétez les informations ci-dessous, détachez la carte au niveau de la perforation, puis l'envoyer à l'adresse spécifiée ci-dessous. Vous pouvez également vous inscrire en ligne en visitant:

Gracias por comprar un producto Omcan usted. Para registrar su garantía para este producto, complete la información a continuación, cortar la tarjeta en la perforación y luego enviarlo a la dirección indicada a continuación. También puede registrarse en línea en:

<https://omcan.com/warranty-registration/>

For mailing in Canada

Pour postale au Canada

Por correo en Canadá

OMCAN

PRODUCT WARRANTY REGISTRATION

3115 Pepper Mill Court,

Mississauga, Ontario

Canada, L5L 4X5

For mailing in the US

Pour diffusion aux États-Unis

Por correo en los EE.UU.

OMCAN

PRODUCT WARRANTY REGISTRATION

4450 Witmer Industrial Estates, Unit 4,

Niagara Falls, New York

USA, 14305

or email to: service@omcan.com



Purchaser's Information

Name: _____

Address: _____

City: _____ Province or State: _____ Postal or Zip: _____

Country: _____

Dealer from which Purchased: _____

Dealer City: _____ Dealer Province or State: _____

Invoice: _____

Model Name: _____ Model Number: _____

Machine Description: _____

Date of Purchase (MM/DD/YYYY): _____

Would you like to extend the warranty? Yes No

Company Name: _____

Telephone: _____

Email Address: _____

Type of Company:

Restaurant Bakery Deli

Butcher Supermarket Caterer

Institution (specify): _____

Other (specify): _____

Serial Number: _____

Date of Installation (MM/DD/YYYY): _____

Thank you for choosing Omcan | Merci d'avoir choisi Omcan | Gracias por elegir Omcan



Since 1951 Omcan has grown to become a leading distributor of equipment and supplies to the North American food service industry. Our success over these many years can be attributed to our commitment to strengthen and develop new and existing relationships with our valued customers and manufacturers. Today with partners in North America, Europe, Asia and South America, we continually work to improve and grow the company. We strive to offer customers exceptional value through our qualified local sales and service representatives who provide convenient access to over 5,000 globally sourced products.

Depuis 1951 Omcan a grandi pour devenir un des “leaders” de la distribution des équipements et matériel pour l’industrie des services alimentaires en Amérique du Nord. Notre succès au cours de ces nombreuses années peut être attribué à notre engagement à renforcer et à développer de nouvelles et existantes relations avec nos clients et les fabricants de valeur. Aujourd’hui avec des partenaires en Amérique du Nord, Europe, Asie et Amérique du Sud, nous travaillons continuellement à améliorer et développer l’entreprise. Nous nous efforçons d’offrir à nos clients une valeur exceptionnelle grâce à nos ventes locales qualifiées et des représentants de service qui offrent un accès facile à plus de 5000 produits provenant du monde entier.

Desde 1951 Omcan ha crecido hasta convertirse en un líder en la distribución de equipos y suministros de alimentos en América del Norte industria de servicios. Nuestro éxito en estos años se puede atribuir a nuestro compromiso de fortalecer y desarrollar nuevas relaciones existentes con nuestros valiosos clientes y fabricantes. Hoy con socios de América del Norte, Europa, Asia y América del Sur, que trabajan continuamente para mejorar y crecer la empresa. Nos esforzamos por ofrecer a nuestros clientes valor excepcional a través de nuestro local de ventas y representantes de los servicios que proporcionan un fácil acceso a más de 5,000 productos con origen a nivel mundial.

